

DISASSEMBLY

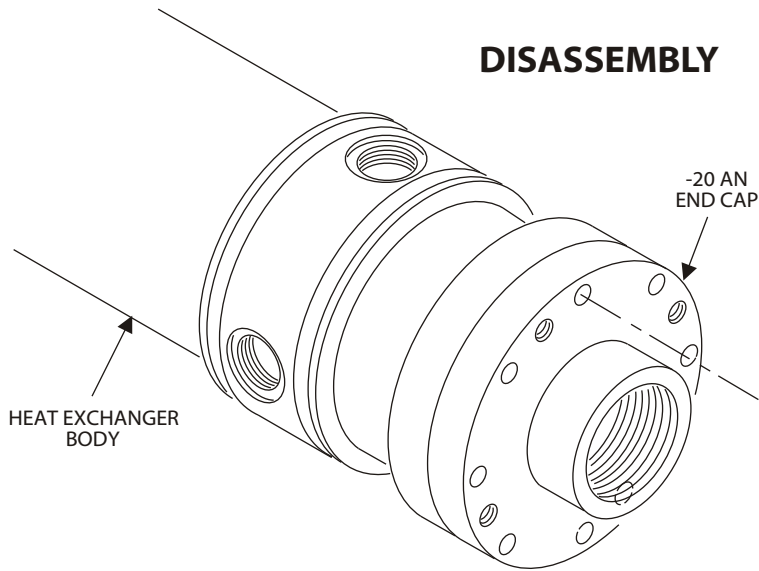

STEP 1

REMOVE EIGHT 10-24 x 3/4" ZINC ALLEN SCREWS SECURING THE END CAP TO THE HEAT EXCHANGER BODY

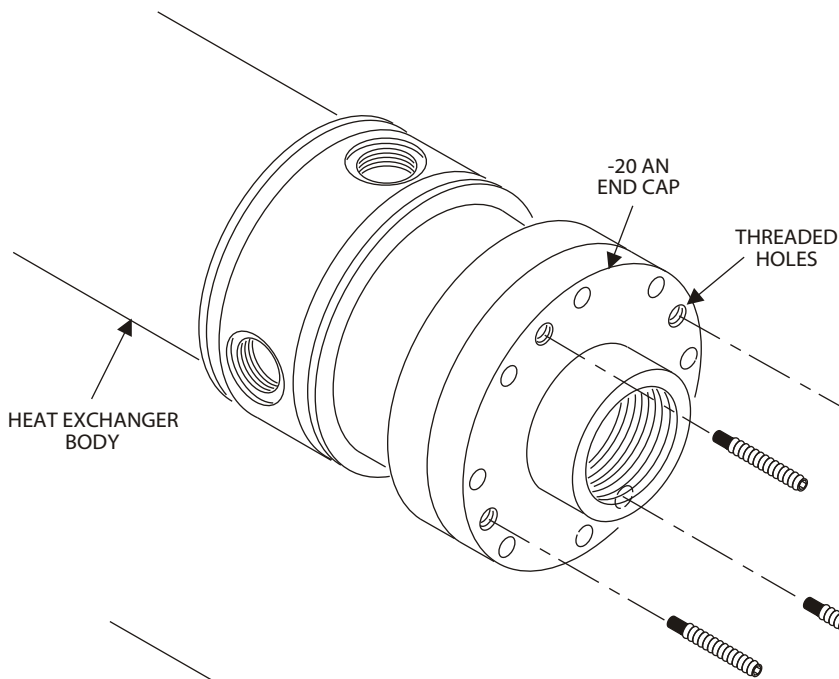

STEP 2

INSERT 1/4-20 x 1" NYLON TIPPED ALLEN JACKING SCREWS INTO THE 4 THREADED HOLES ON THE END CAP.

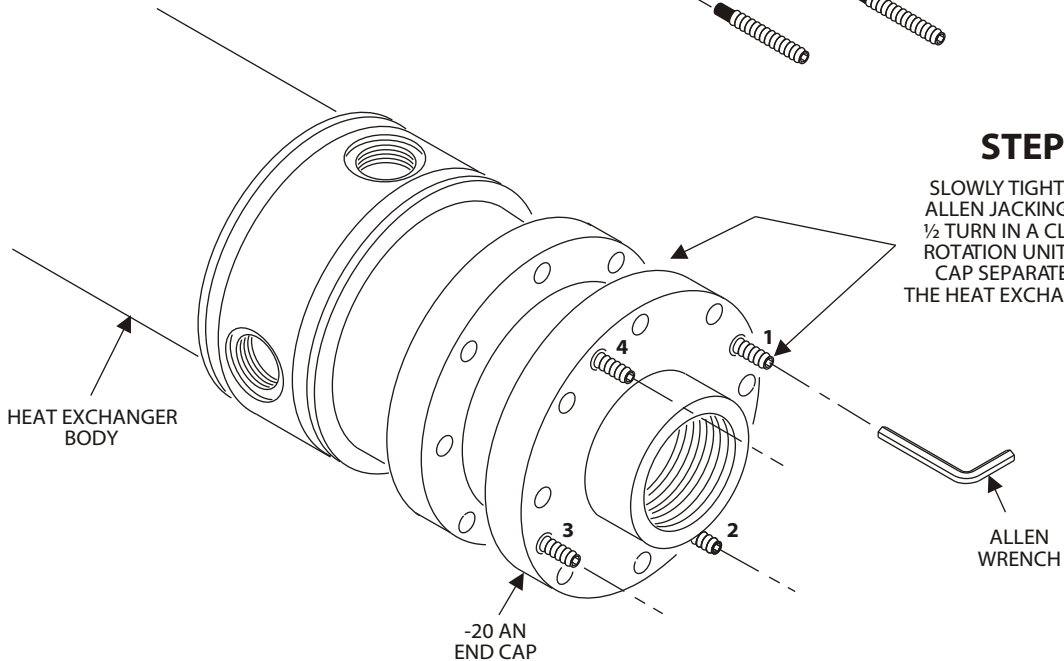

STEP 3

SLOWLY TIGHTEN EACH ALLEN JACKING SCREWS 1/2 TURN IN A CLOCKWISE ROTATION UNIT THE END CAP SEPARATES FROM THE HEAT EXCHANGER BODY